

## 塑封硅整流桥堆

反向电压 600V  
正向电流 2.0 A

## Single-phase Silicon Bridge Rectifier

Reverse Voltage 600 V  
Forward Current 2.0 A

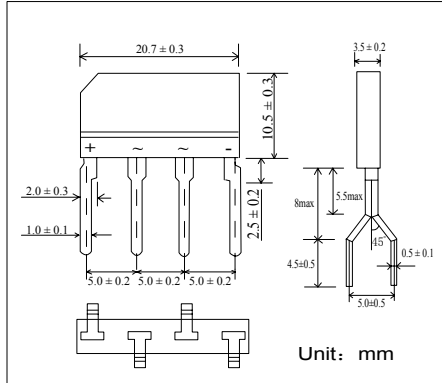

## 特征 Features

- 低的反向漏电流 Low reverse leakage
- 较强的正向浪涌承受能力 High forward surge capability
- 浪涌承受能力: 80 A Surge overload rating: 80 Amperes peak

## 机械数据 Mechanical Data

- 封装: 塑料封装 Case: Molded Plastic
- 极性: 标记模压或印于本体 Polarity: Symbols molded or marked on body
- 安装位置: 任意 Mounting Position: Any

极限值和温度特性 TA = 25°C 除非另有规定。

Maximum Ratings & Thermal Characteristics Ratings at 25°C ambient temperature unless otherwise specified.

	符号 Symbols	D2SB60	单位 Unit
最大可重复峰值反向电压 Maximum repetitive peak reverse voltage	$V_{RRM}$	600	V
最大均方根电压 Maximum RMS voltage	$V_{RMS}$	420	V
最大直流阻断电压 Maximum DC blocking voltage	$V_{DC}$	600	V
最大正向平均整流电流 Maximum average forward rectified current	$I_{F(AV)}$	2.0	A
峰值正向浪涌电流 8.3ms单一正弦半波 Peak forward surge current 8.3 ms single half sine-wave	$I_{FSM}$	80	A
最大反向峰值电流 @TA = 75°C Maximum peak reverse current full cycle	$I_{R(AV)}$	30	μA
典型热阻 Typical thermal resistance	$R_{\theta JA}$	15	°C/W
工作结温和存储温度 Operating junction and storage temperature range	T <sub>j</sub> , T <sub>STG</sub>	-55 --- +150	°C

电特性 TA = 25°C 除非另有规定。

Electrical Characteristics Ratings at 25°C ambient temperature unless otherwise specified.

	符号 Symbols	D2SB60	单位 Unit
最大正向电压 I <sub>F</sub> = 1.0A Maximum forward voltage	$V_F$	1.05	V
最大反向电流 TA= 25°C Maximum reverse current TA= 125°C	$I_R$	10 500	μA
典型结电容 V <sub>R</sub> = 4.0V, f = 1MHz Type junction capacitance	$C_j$	40	pF

特性曲线 Characteristic Curves

